



# SEAL KIT INSTRUCTION SHEET

## INSTALLATION OF SEALS, BEARINGS, AND RELATED PARTS IN THE PUMPING SECTION OF THE -4 AND -5 FAMILY OF 5-3/4" DRIVE LIQUID PUMPS, AIR AMPLIFIERS AND GAS BOOSTERS.

### INSTRUCTIONS:

To install upper and lower sets of rod seals and bearings: Fit 568116-7 O-rings firmly around 26165-2 seals. Tilt seals into 16778 body as shown, so O-ring will face bearing. Squeeze 27908 bearing so that ends overlap. Insert into 16778 body and allow to expand into cavity. Insert piston rod through bearing section with rod insertion tool 56198.

To assemble the high pressure section put the cupped 17124 piston bumper in the pump body with the concave side facing in. Place the O-ring behind the bumper and install the 17517 sleeve. Put the piston rod in approximately the position shown and push the 17983 piston assembly over the rod until it is seated against the shoulder. Place the 568015-7 O-ring over the rod into the counterbore of the piston assembly. Slide the 17527 piston ring into the bore so it is in full contact with the piston assembly. Press the 568330-7 O-ring between the piston ring and the recess in the piston assembly. Put the 17984 spacer assembly in place and screw the nut down until snug. Back the nut off to the nearest hole and tap in the spiral pin flush with nut.

NOTE: Install all parts dry. Do not use lubrication of any kind.

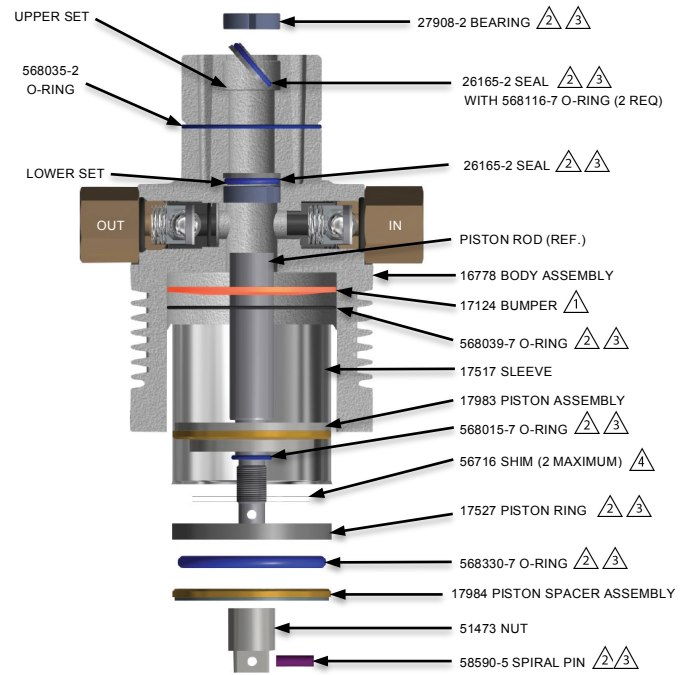

CHECK VALVES  
GAS PUMP  
MODELS:  
AAD-5, AG-4,  
AGD-4, AND AGT-4

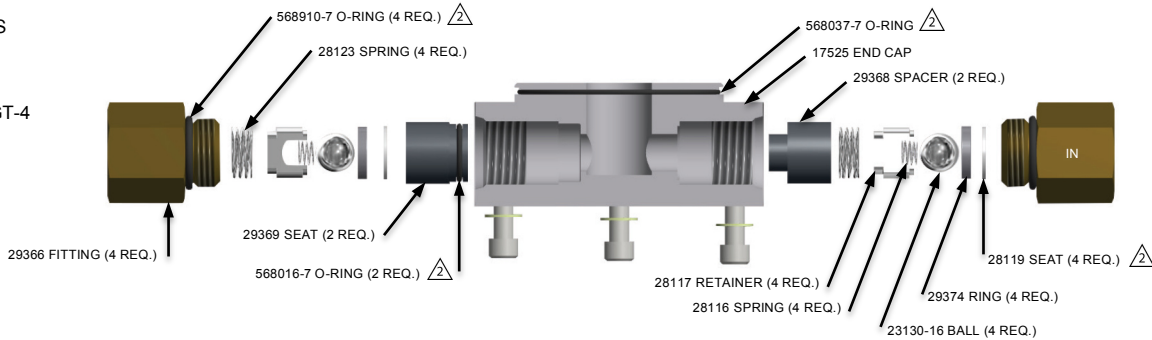

CHECK VALVES  
LIQUID PUMP  
MODELS:  
ATV-4 OR DTV-4

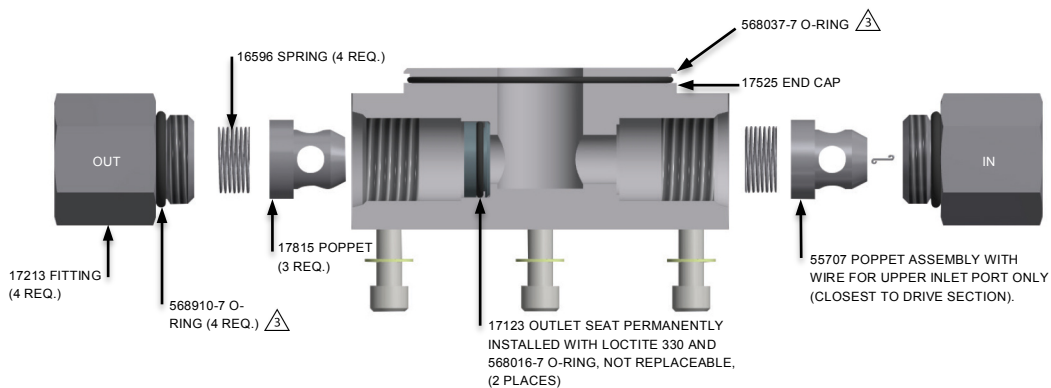

- 1 17124 BUMPERS IS NOT USED ON LIQUID PUMP MODELS
- 2 PART INCLUDED IN SEAL KIT 29013
- 3 PART INCLUDED IN SEAL KIT 29017
- 4 USE ONE OF TWO SHIMS TO ENSURE NO SLACK BETWEEN PARTS AFTER 58690-6 SPIRAL PIN IS INSTALLED

### REFERENCES:

26267	29016
18059	29017
29013	29470
29015	52136